

TECHNICAL SPECIFICATION

Lubricator – L38

Product Description

Performance

Construction

Accessories and Spare Parts

How to Order

Dimensional Details

PRODUCT DESCRIPTION

Wilkerson L Series Economist Lubricators inject an oil aerosol into the flowing air stream to automatically provide the proper amount of internal lubrication to air valves, cylinders, air motors, air tools, and other pneumatic devices requiring lubrication.

Features

- Combination sight glass and adjusting knob for adjustment of lubrication over a wide range of applications.
- Can be refilled with oil while under pressure. No interruption of production necessary to refill.
- Oil pick-up siphon tube has a sintered bronze filter, standard, to remove contaminants that could block lubrication passages.
- Standard plastic bowl and bowl guard with multiple viewing slots.
- Barbed manual drain connection with pipe-away.
- Bayonet-type bowl mount for ease of service.
- High flow capacity in an efficient, compact package.
- Installs Modular or Hard-Piped.
- Reverse flow capability with minimal oil migration.

Operation

Air flow enters lubricator at inlet (A). A portion of the air entering the lubricator passes the bowl pressure control valve (B). This air (C) is used to push the lubricant up the siphon tube (E) into the metering knob/sight glass assembly (F) for delivery to the nozzle passage and into the lubricator throat (G). The Flow-Guide (H) creates a slight pressure drop that is proportional to the rate of air flow. This slight pressure drop allows the air in the bowl to push the oil up the siphon tube. At low air flows, most of the air goes through the orifice in the centre of the Flow-Guide. As the air flow increases, the Flow-Guide allows a portion of the air stream to by pass, automatically maintaining a constant oil-to-air ratio over a wide range of changing air flows. A check valve (not shown) keeps siphon tube full of oil during periods of no air flow. All of the drops visible in the sight dome (F) are delivered in atomised form to air devices downstream. Manual drain (J) allows water to be drained out when necessary. Sintered oil filter (D) removes solid contaminants in oil.

Suggested Lubricant

Wilkerson recommends using a light weight, non-detergent oil, such as an ISO/ASTM VG32. Most major oil suppliers have a grade of oil specifically formulated as an "air line lubricant", or "air tool lubricant".

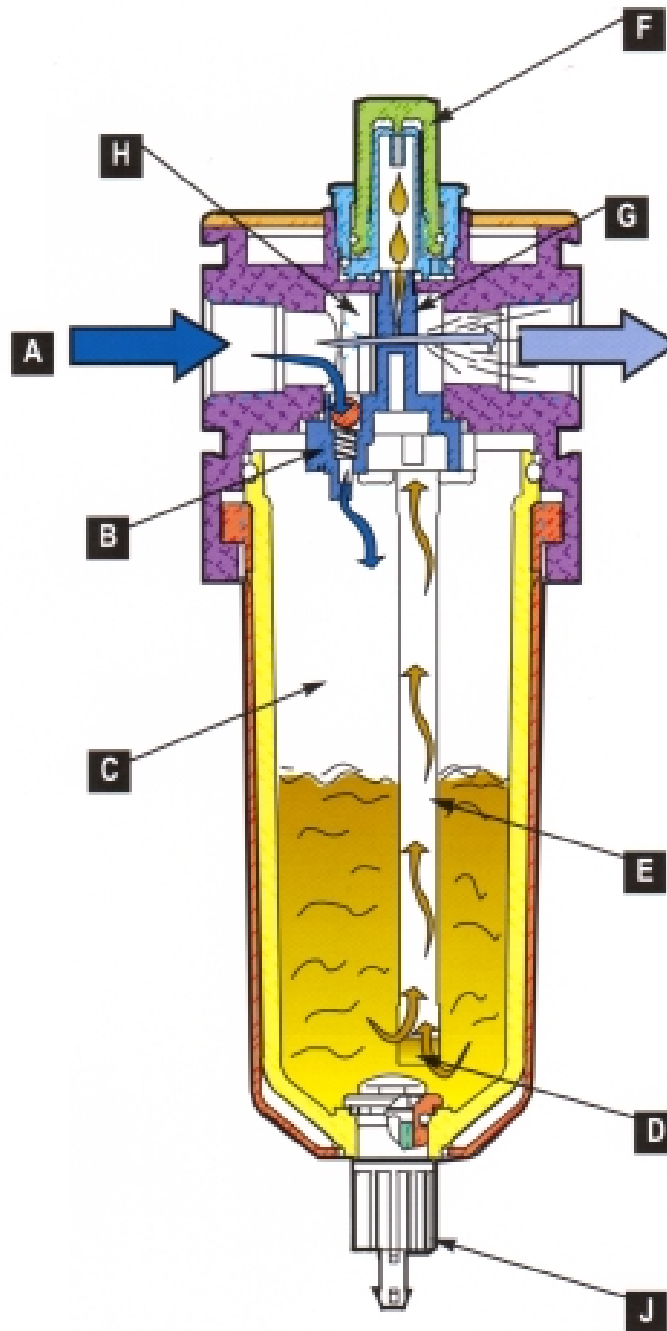

PERFORMANCE

Port Size	BSPP-G (ISO228)	3/4, 1
Flow Capacity*	3/4 1	285 scfm (134 dm ³ /s) 440 scfm (207 dm ³ /s)
Maximum Operating Temperature	Plastic Bowl Metal Bowl	125°F (52°C) 150°F (65,5°C)
Maximum Supply Pressure	Plastic Bowl Metal Bowl	150 psig (10,3 bar) 250 psig (17,2 bar)
Useful Retention	oz. (cm ³)	19 (539)
Weight	lb. (kg)	3.9 (1,9)

* Inlet pressure 150 psig (6,9 bar). Pressure drop 5 psid (0,3 bar).

CONSTRUCTION

Body		Aluminium
Body Cap		ABS
Bowl	Plastic Bowl Metal Bowl	Polycarbonate Aluminium
Seals	Plastic Bowl Metal Bowl	Nitrile Nitrile
Sight Dome		Polycarbonate
Sight Gauge	Metal Bowl	Nylon
Suggested Lubricant		ISO/ASTM VG32
Pick-up Filter		Sintered Bronze

ACCESSORIES AND SPARE PARTS

Replacement Bowl Kits

Metal Bowl with Sight Gauge, Manual Drain	GRP-96-689
Plastic Bowl/Bowl Guard, Manual Drain	LRP-96-703

Replacement Kits

Sight Dome Assembly	LRP-96-710
Fill Plug Kit (O-ring only)	LRP-96-698
Flow Guide	LRP-96-697
Bowl O-ring, Nitrile	GRP-96-693
Sight Dome Assembly	LRP-96-710

Accessories

Wall Mounting Bracket, C-Type	GPA-96-609
-------------------------------	------------

HOW TO ORDER

Lubricator Numbering System

L 1 8 - 0 3 - L K D T

L Unit Function

L = Lubricator

1 Family

- 8** 08 = Miniature
- 18 = Compact
- 28 = Standard
- 38 = Jumbo (Not all configurations are available for the L38 Series Lubricator. Refer to price list.)

0 Thread Type

- 0 = NPT
- C = BSPP (ISO, R228 [G Series])

3 Pipe Size

- 1 = 1/8 4 = 1/2
- 2 = 1/4 6 = 3/4
- 3 = 3/8 8 = 1

L Lubricator

L = ECONOMIST

K Bowls/Drains

Drains	Plastic w/guard Nitrile Standard	Metal w/sight glass ¹ Fluorocarbon Standard
None	C	D
Manual Drain	K	L

¹L08 Lubricator has an all metal bowl (no sight gauge)

D Options

- 0 = None
- D = Force Fill Adapter
- T = Tamper Resistant Cap
- V = Fluorocarbon Seals

T Options

- 0 = None
- D = Force Fill Adapter
- T = Tamper Resistant Cap
- V = Fluorocarbon Seals

Note: When selecting from the options columns, please enter letters in alphabetical order, for example:

L18 - 03 - L K D T

DIMENSIONAL DETAILS

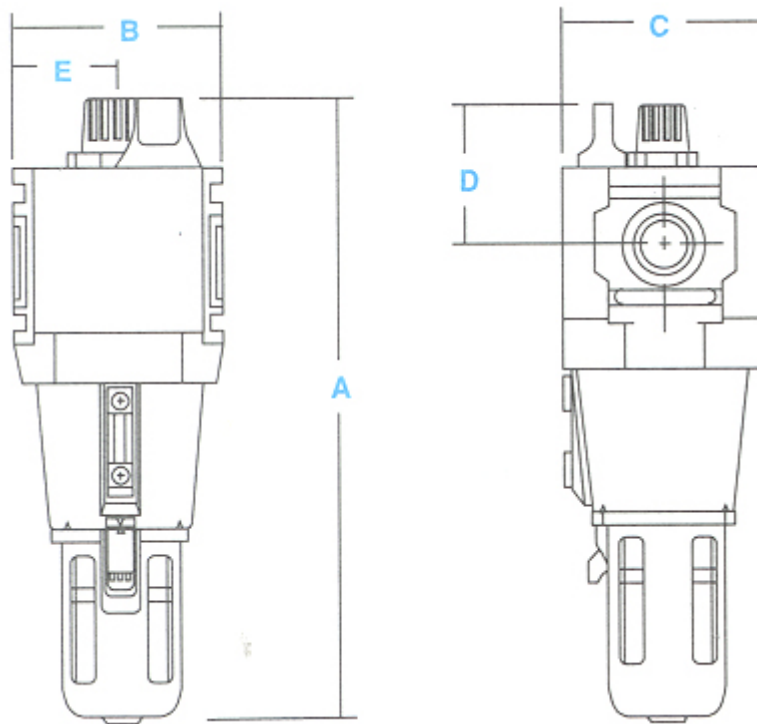

Models	A mm (inches)	B mm (inches)	C mm (inches)	D mm (inches)	E mm (inches)
Standard Unit L38-XX-LK00	143.5 (5.65)	40.0 (1.58)	42.7 (1.68)	45.5 (1.79)	21.3 (0.84)
Metal Bowl with Sight Gauge	271 (10.67)	100 (3.94)	100 (3.94)	54 (2.13)	52 (2.05)