

TECHNICAL SPECIFICATION

Coalescing Filter – M08



Product Description



Performance



Construction



Accessories and Spare Parts



How to Order



Dimensional Details



PRODUCT DESCRIPTION

Wilkerson M Series Microalescer Coalescing [oil removal] Air Filters are highly efficient at removing dirt, rust, pipe scale and other particulate contaminants down to 0.01 micron in size and are over 99.99998% efficient at separating out liquid water and oils with low pressure drops at rated flows. They are used where the highest quality air is required. A Wilkerson F Series particulate filter should be used as a prefilter to assure maximum element life.

Features

- Extremely efficient at oil removal, <0.01ppm/wt oil carryover.
- Wide range of available elements, including 0.5 micron, 0.01 micron and activated carbon for oil vapour removal (0.003ppm/wt).
- Rugged element construction prevents element collapse at high differential pressures.
- Differential pressure indicator (H) is standard on 18 Series and larger
- Standard bowl guard with multiple viewing slots.
- Barbed manual drain connection with pipe-away.
- Bayonet-type bowl mount for ease of service.
- High flow capacity in an efficient, compact package.
- Fluorocarbon seals standard.

Operation

Air enters at inlet port (A) and flows into the inside of the coalescing element (B). Air passes from inside to outside the element, through the microborosilicate filter media (B), where solid dirt particles are captured mechanically. The aerosols of oil and water (liquid) are coalesced by the mechanisms of direct interception, inertial impaction, and diffusion (Brownian Movement). The coalesced liquids are then pushed to the outside of the element, where the anti-re-entrainment barrier (C) collects the droplets as they break free of the micro fibre media. This forms a "wet band" at the bottom of the filter element, and gravity pulls the liquid off the element and it collects in the bottom of the bowl (D), to be drained off by the drain (E).

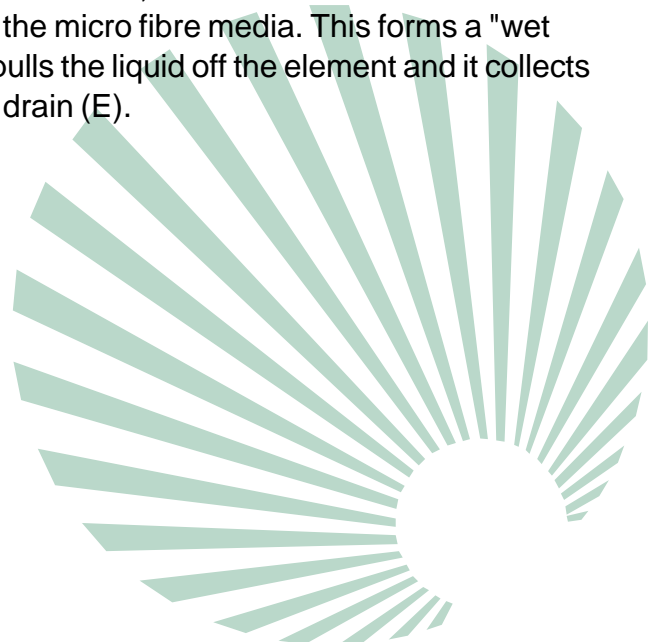

Note: Wilkerson recommends the use of automatic drains in coalescing filters. The clean, oil-free air then moves from the bowl (F) to the filter outlet and downstream (G). Differential pressure indicator (H) lets you know when element needs changing.

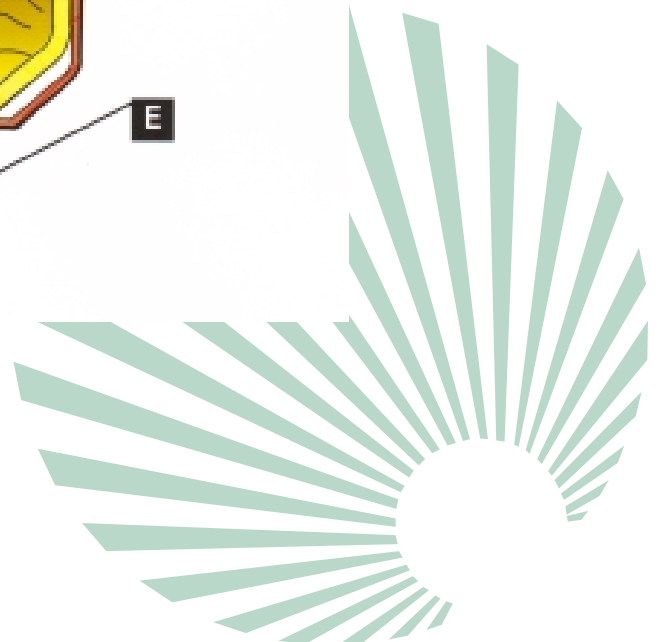
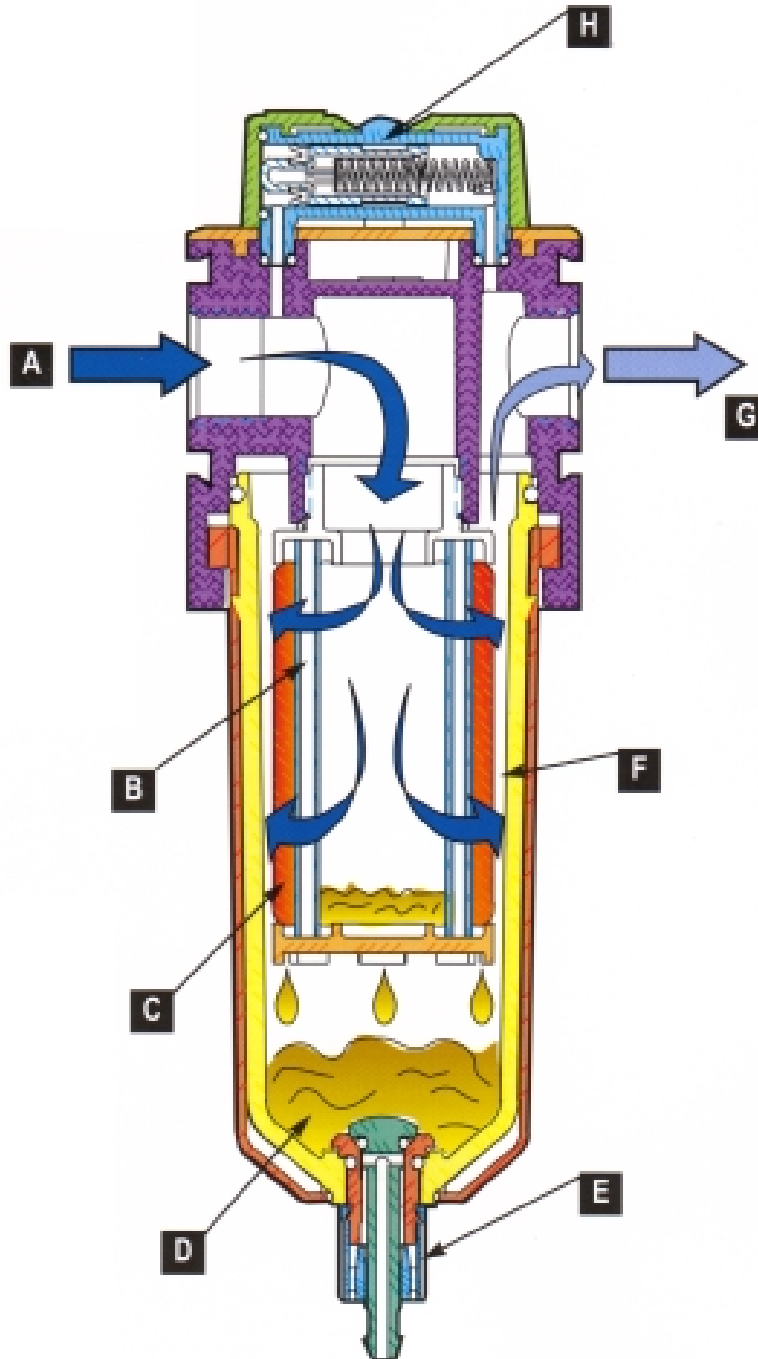

PERFORMANCE

Port Size	BSPP-G (ISO228)	1/4
Flow Capacity*	1/4	11.0 scfm (5,2 dm ³ /s)
Maximum Operating Temperature	Plastic Bowl Metal Bowl	125°F (52°C) 150°F (65,5°C)
Maximum Supply Pressure	Plastic Bowl Metal Bowl	150 psig (10,3 bar) 250 psig (17,2 bar)
Standard Filtration	Micron	(B) 0.5, (C) 0.01 (D) 0.003 ppm wt**
Useful Retention***	oz (cm ³)	0.4 (12)
Weight	lb (kg)	0.4 (0,2)

* Inlet pressure 150 psig (10,3 bar). Pressure drop 3 psid (0,2 bar) (dry element).

** Filtration temperature of 70°F (21°C) @ 100 psig (6,9 bar) with typical compressor lubricating oil and protected by Type C filter.

*** Useful retention refers to volume below the quiet zone baffle.

"M" series Coalescing Filters with Type "B" 0.5 micron elements:

All Wilkinson Type "M" Oil Removal (Coalescing) Filters with Type "B" 0.5 micron elements exceed ISO Class 2 for maximum particle size and concentration of solid contaminants, and exceed Class 3 on maximum oil content (ppm/wt)

"M" series Coalescing Filters with Type "C" 0.01 micron elements:

All Wilkinson Type "M" Oil Removal (Coalescing) Filters with Type "C" 0.01 micron elements exceed ISO Class 1 for maximum particle size and concentration of solid contaminants, and exceed Class 1 on maximum oil content (ppm/wt)

"M" Series Adsorption Filters, with Type "D" activated carbon elements:

All Wilkinson Type "M" adsorption filters with Type "D" activated carbon elements exceed ISO Class 1 on maximum oil content (ppm/wt).

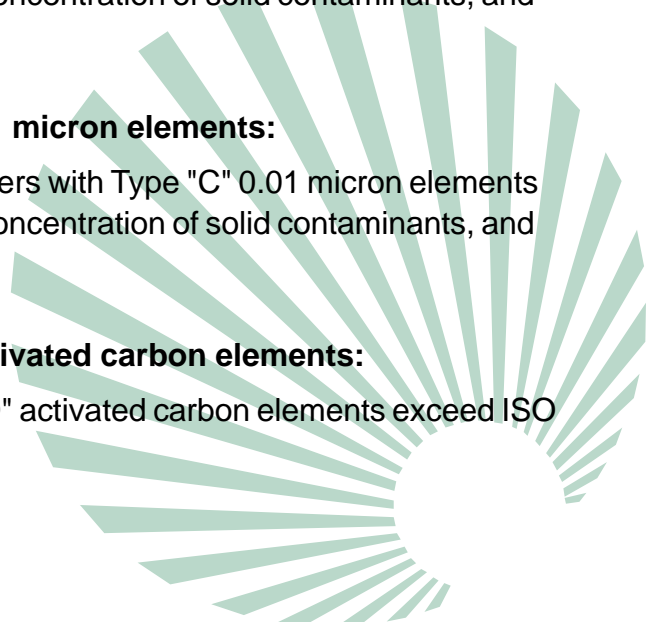

CONSTRUCTION

Body		Zinc
Body Cap		ABS
Bowl	Plastic Bowl Metal Bowl	Polycarbonate Zinc
Filter Element	Type B, C Type D	Borosilicate Cloth Activated Carbon
Seals		Nitrile



ACCESSORIES AND SPARE PARTS

Replacement Bowl Kits

Plastic Bowl/Bowl Guard, Manual Drain	GRP-96-712
Metal Bowl, Manual Drain	GRP-96-714

Replacement Element Kits

Type C 0.01 Micron	MTP-96-649
Type B 0.5 Micron	MSP-96-732
Type D 0.003 Micron, Activated Carbon	MPX-96-222

Accessories

Automatic Piston Drain	GRP-96-716
Wall Mounting Bracket, C-Type	GPA-97-010
Wall Mounting Bracket, T-Type	GPA-96-737



HOW TO ORDER

Coalescing Numbering System

M 1 8 - 0 3 - C K 0 0

M Unit Function

M = Coalescing Filter

1 Family

8 08 = Miniature

18 = Compact

28 = Standard

0 Thread Type

0 = NPT

C = BSPP (ISO, R228 [G Series])

3 Pipe Size

1 = 1/8

4 = 1/2

2 = 1/4

6 = 3/4

3 = 3/8

8 = 1

C Coalescing – DP8 STD

B = .5 Micron, oil removing

C = .01 Micron, oil removing

D = .003 Micron, oil adsorption activated carbon

K Bowls/Drains

Drains

Plastic w/guard
Nitrile Standard

Metal w/sight glass¹
Fluorocarbon Standard

None

C

D

1/8 NPT Female²

E

F

Std Auto Drain²

G

H

Manual Drain

K

L

Low Flow Auto Drain²

N

P

Piston Drain (B08 only)

R

S

¹M08 Filter has an all metal bowl (no sight gauge)

²Except 08 Series

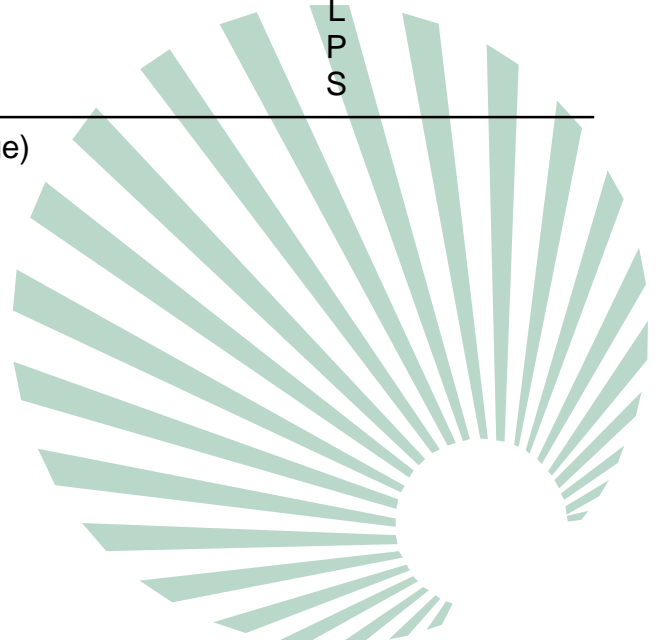

0 Options

- 0 = None
- M = No differential pressure indicator
(For operating pressure over 150 psig [10 bar])

0 Options

- 0 = None
- M = No differential pressure indicator
(For operating pressure over 150 psig [10 bar])

Note: When selecting from the options columns, please enter letters in alphabetical order, for example:

M18 – 03 – L K 0 0

"M" series Coalescing Filters with Type "B" 0.5 micron elements:

All Wilkinson Type "M" Oil Removal (Coalescing) Filters with Type "B" 0.5 micron elements exceed ISO Class 2 for maximum particle size and concentration of solid contaminants, and exceed Class 3 on maximum oil content (ppm/wt)

"M" series Coalescing Filters with Type "C" 0.01 micron elements:

All Wilkinson Type "M" Oil Removal (Coalescing) Filters with Type "C" 0.01 micron elements exceed ISO Class 1 for maximum particle size and concentration of solid contaminants, and exceed Class 1 on maximum oil content (ppm/wt)

"M" Series Adsorption Filters, with Type "D" activated carbon elements:

All Wilkinson Type "M" adsorption filters with Type "D" activated carbon elements exceed ISO Class 1 on maximum oil content (ppm/wt).

Note: All classes above refer to International Standards Organisation (ISO) standard 8573-1:1991 (E), pertaining to maximum particle size and concentration of solid contaminants, and maximum oil content.

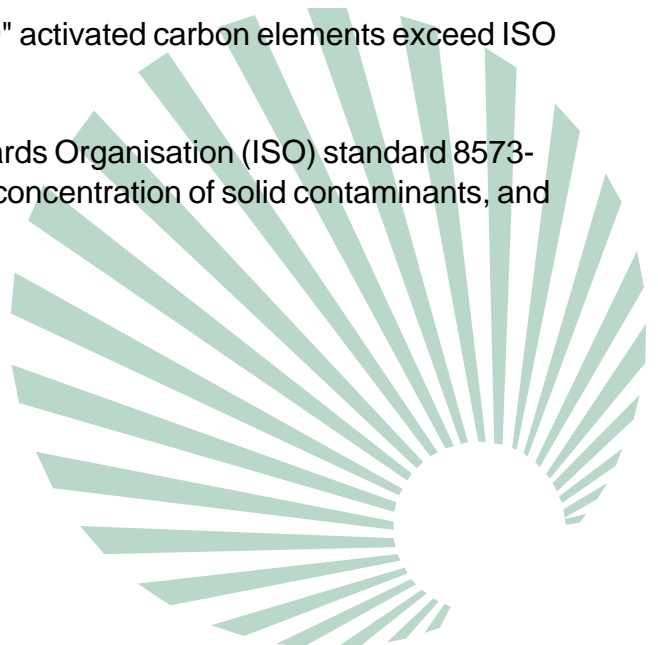

DIMENSIONAL DETAILS

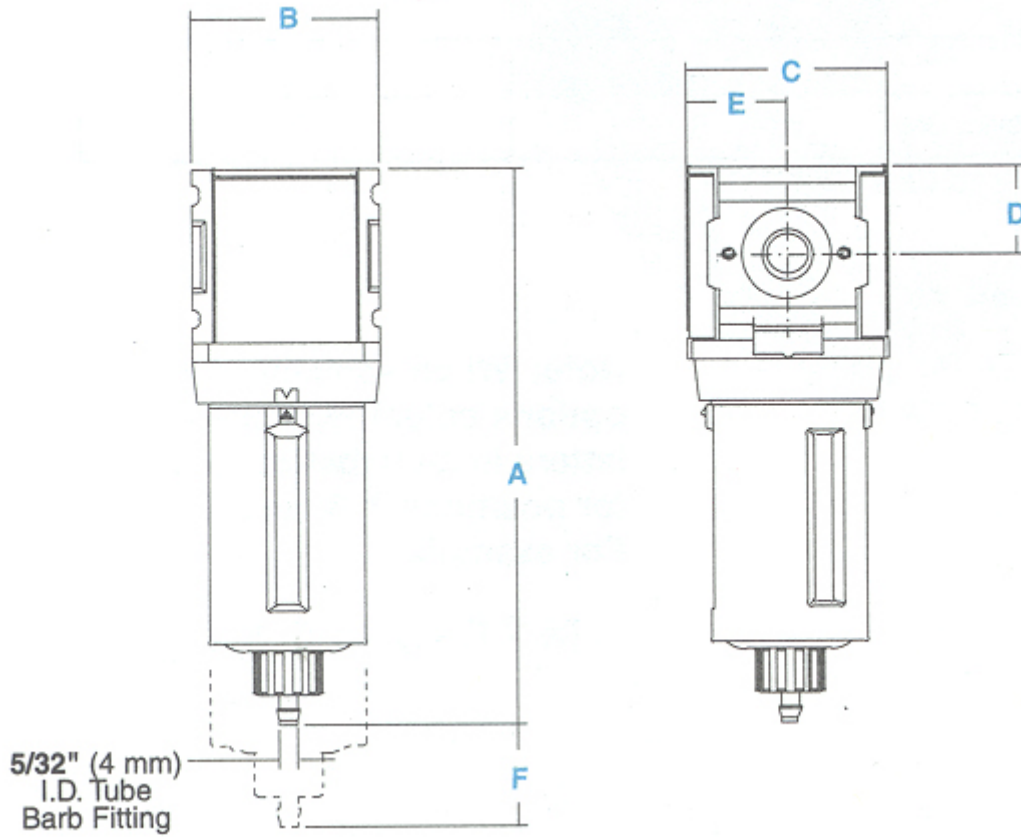

Models	A mm (inches)	B mm (inches)	C mm (inches)	D mm (inches)	E mm (inches)	F mm (inches)
Standard Unit M08-XX-CK00	116.3 (4.58)	40.0 (1.58)	42.7 (1.68)	18.3 (0.72)	21.3 (0.84)	33.3 (1.31)

