

## TECHNICAL SPECIFICATION *FRL Combinations – C38*



**Product Descriptions**



**Performance**



**Construction**



**How To Order**



**Dimensional Details**



## PRODUCT DESCRIPTION

### Filters

Wilkerson F Series Air Filters are highly efficient at removing dirt, rust, pipe scale and other particulate contaminants down to 5 microns in size - and are over 97% efficient at separating out liquid water and oils with low pressure drops at rated flows!

### Features

- Extremely efficient at water separation/removal (>97%)
- Special Whirl-Flo baffle creates a cyclonic flow, ensuring maximum separation of dirt and water from air.
- 5 micron element has always been Wilkerson's standard.
- Sintered depth-type element for high dirt-holding capacity.
- Standard bowl guard with multiple viewing slots.
- Barbed manual drain connection with pipe-away.
- Bayonet-type bowl mount for ease of service.
- Can be installed modular or hard-piped.

### Operation

#### **Separation**

Air enters at inlet port (A) and flows through the Whirl-flo baffle (B), creating a cyclonic swirling flow (C). Liquids and large solid particles are centrifugally forced to the inner wall of the bowl, where gravity moves them to the quiet zone (F), below the quiet zone baffle (D), which prevents re-entrainment of the collected liquids into the air stream. Accumulated liquids are drained off by opening the manual drain valve (G).

#### **Filtration**

After liquids and large solid particles are separated from the air stream, the air then flows through the element (E), where dirt particles down to 5 microns in size are filtered out. The filtered air stream exits the filter (H) and continues downstream.

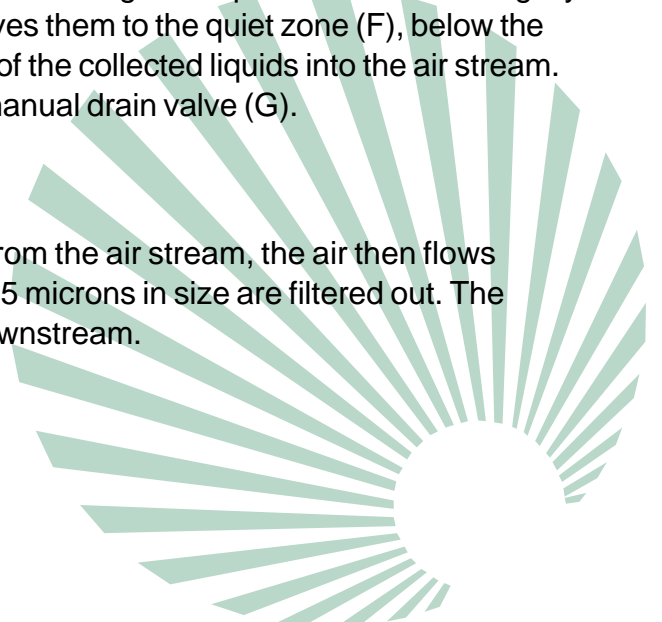
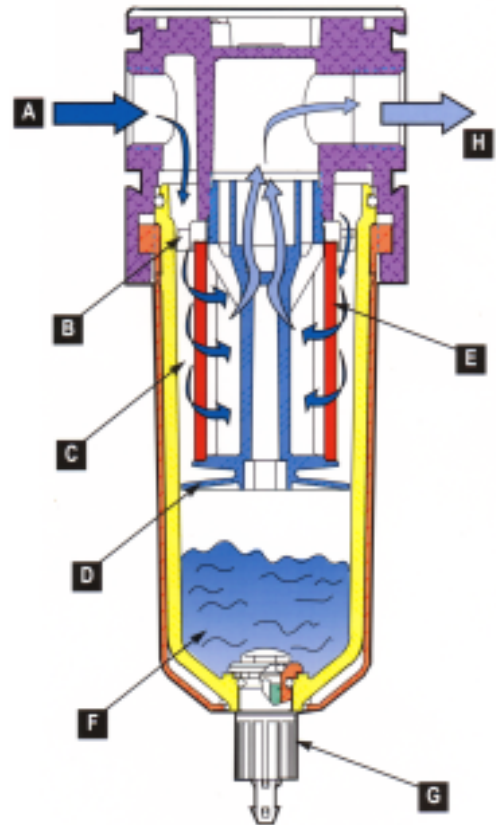

## Regulators

Wilkerson. R Series Air Regulators are designed with balanced valves for high performance flows and good regulation characteristics in a compact package.

### Features

- Balanced valve design for better performance at higher flows.
- Non-rising knob with snap lock is standard.
- Diaphragm design for optimum sensitivity, response and repeatability.
- Panel nut is standard.
- 2 gauge ports standard.
- Wide range of available spring ranges and port sizes.
- Easy service access to main valve assembly.
- Reverse flow option available.
- Can be installed modular or hard piped.

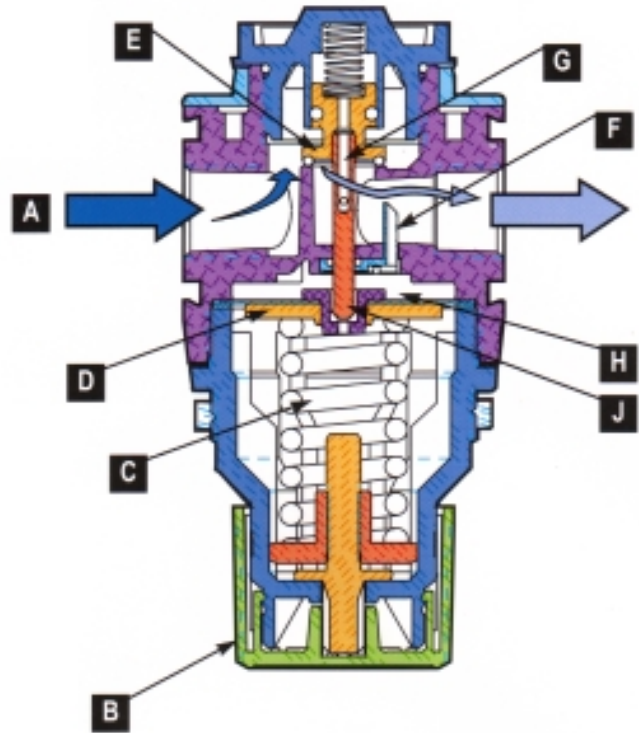

### Operation

Air flow enters regulator at (A). Turning adjusting knob (B) clockwise [viewed from knob end] compresses the main spring (C), causing diaphragm (D) and main valve (E) to move, allowing flow across valve seat area. Pressure in the downstream area is sensed through the aspirator tube (F) to the area under the diaphragm (H). As downstream pressure rises, it offsets the load of spring (C). The diaphragm (D) and valve (E) move to close valve against its seat, stopping air flow through regulator. Spring pressure (C) and downstream pressure (H) are in balance, at reduced outlet pressure. Any demand downstream, such as opening a valve, will cause the downstream pressure to drop. The main spring (C) will again push open the valve (E), repeating the sequence in a modulating fashion to maintain the downstream pressure setting. In standard relieving models, a rise in downstream pressure above the set pressure will cause the diaphragm (D) to lift off the top of the valve stem (J), thus relieving the excess pressure to atmosphere under the knob (B). When the downstream pressure returns to the set pressure, the diaphragm re-seats on the valve stem, and the system is again in equilibrium.

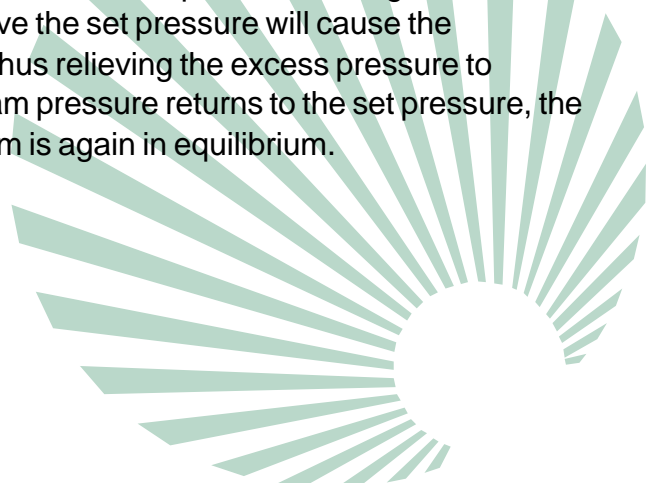

## Lubricators

Wilkerson L Series Economist Lubricators inject an oil aerosol into the flowing air stream to automatically provide the proper amount of internal lubrication to air valves, cylinders, air motors, air tools, and other pneumatic devices requiring lubrication.

### Features

- Combination sight glass and adjusting knob for adjustment of lubrication over a wide range of applications.
- Can be refilled with oil while under pressure. No interruption of production necessary to refill.
- Oil pick-up siphon tube has a sintered bronze filter, standard, to remove contaminants that could block lubrication passages.
- Standard plastic bowl and bowl guard with multiple viewing slots.
- Barbed manual drain connection with pipe-away.
- Bayonet-type bowl mount for ease of service.
- High flow capacity in an efficient, compact package.
- Installs Modular or Hard-Piped.
- Reverse flow capability with minimal oil migration.

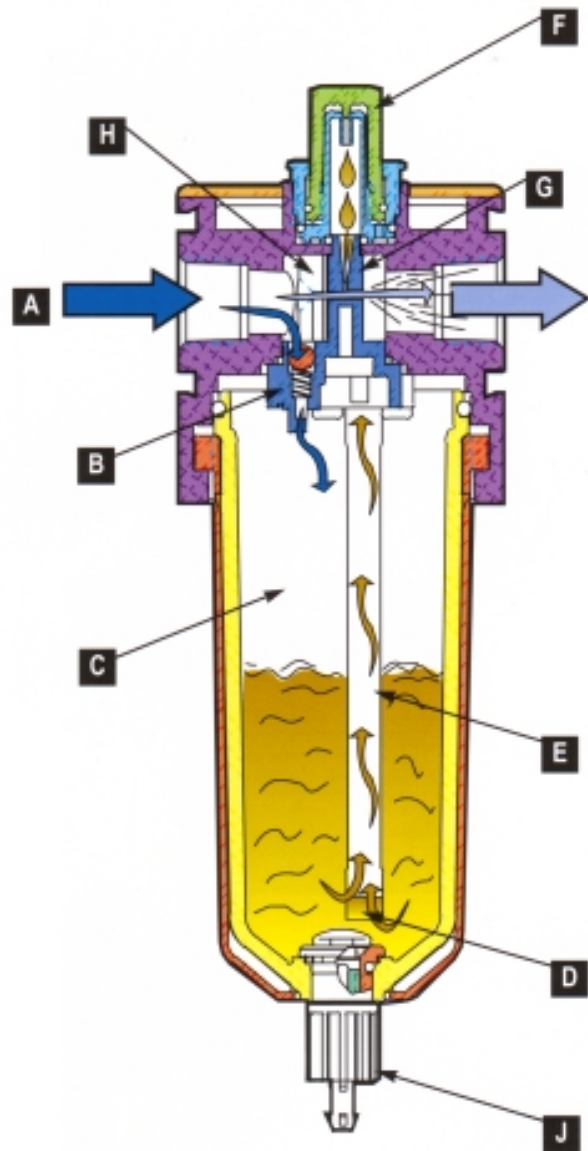

## Operation

Air flow enters lubricator at inlet (A). A portion of the air entering the lubricator passes the bowl pressure control valve (B). This air (C) is used to push the lubricant up the siphon tube (E) into the metering knob/sight glass assembly (F) for delivery to the nozzle passage and into the lubricator throat (G). The Flow-Guide (H) creates a slight pressure drop that is proportional to the rate of air flow. This slight pressure drop allows the air in the bowl to push the oil up the siphon tube. At low air flows, most of the air goes through the orifice in the centre of the Flow-Guide. As the air flow increases, the Flow-Guide allows a portion of the air stream to by pass, automatically maintaining a constant oil-to-air ratio over a wide range of changing air flows. A check valve (not shown) keeps siphon tube full of oil during periods of no air flow. All of the drops visible in the sight dome (F) are delivered in atomised form to air devices downstream. Manual drain (J) allows water to be drained out when necessary. Sintered oil filter (D) removes solid contaminants in oil.

## Suggested Lubricant

Wilkerson recommends using a light weight, non-detergent oil, such as an ISO/ASTM VG32. Most major oil suppliers have a grade of oil specifically formulated as an "air line lubricant", or "air tool lubricant".



## PERFORMANCE

|                               |                            |  |
|-------------------------------|----------------------------|--|
| Port Size                     | BSPP-G (ISO228)            | 3/4, 1                                     |
| Flow Capacity*                | 3/4, 1                     | 348 scfm (164 dm <sup>3</sup> /s)          |
| Maximum Operating Temperature | Plastic Bowl<br>Metal Bowl | 125°F (52°C)<br>150°F (65,5°C)             |
| Maximum Supply Pressure       | Plastic Bowl<br>Metal Bowl | 150 psig (10,3 bar)<br>250 psig (10,3 bar) |
| Standard Filtration           | Micron                     | 5  |
| Useful Retention**            | oz (cm <sup>3</sup> )      | Filter 8.0 (227)<br>Lubricator 19 (539)    |
| Weight                        | lb (kg)                    | 9.72 (4,4)                                 |

\* Inlet pressure 150 psig (6,9 bar). Secondary pressure 90 psid (6,2 bar).

\*\* Useful retention refers to volume below the quiet zone baffle.

### "F" Series Filters, Type "A" 5 micron elements

All Wilkerson Type "A" 5 micron elements meet or exceed ISO Class 3 for maximum particle size and concentration of solid contaminants.



## CONSTRUCTION

|                    |                            |                       |
|--------------------|----------------------------|-----------------------|
| Body               |                            | Aluminium             |
| Bowl               | Plastic Bowl<br>Metal Bowl | Polycarbonate<br>Zinc |
| Bonnet/Knob        |                            | Nylon/Acetal          |
| Element Retainer   |                            | Polyamide             |
| Filter Element     |                            | Polyethylene          |
| Seals              | Plastic Bowl<br>Metal Bowl | Nitrile<br>Nitrile    |
| Springs            |                            | Steel                 |
| Valve Assembly     |                            | Brass/Acetal/Nitrile  |
| Diaphragm Assembly |                            | Nitrile/Zinc          |
| Fill Plug          |                            | Polyacetal            |
| Sight Dome         |                            | Polycarbonate         |



## HOW TO ORDER

| Model Type   | Port Size | Plastic Bowl/Bowl Guard with Gauge<br>7-125 psi (0,4-8,6 bar) | Plastic Bowl/Bowl Guard without Gauge<br>7-125 psi (0,4-8,6 bar) | Metal Bowl/Sight Gauge with Gauge<br>7-125 psi (0,4-8,6 bar) |
|--------------|-----------|---|--|--|
| Manual Drain | 3/4       | C38-C6-FKG0   | C38-C6-FK00  | C38-C6-FHG0  |
|              | 1         | C38-C8-FKG0   | C38-C8-FK00  | C38-C8-FHG0  |



## DIMENSIONAL DETAILS

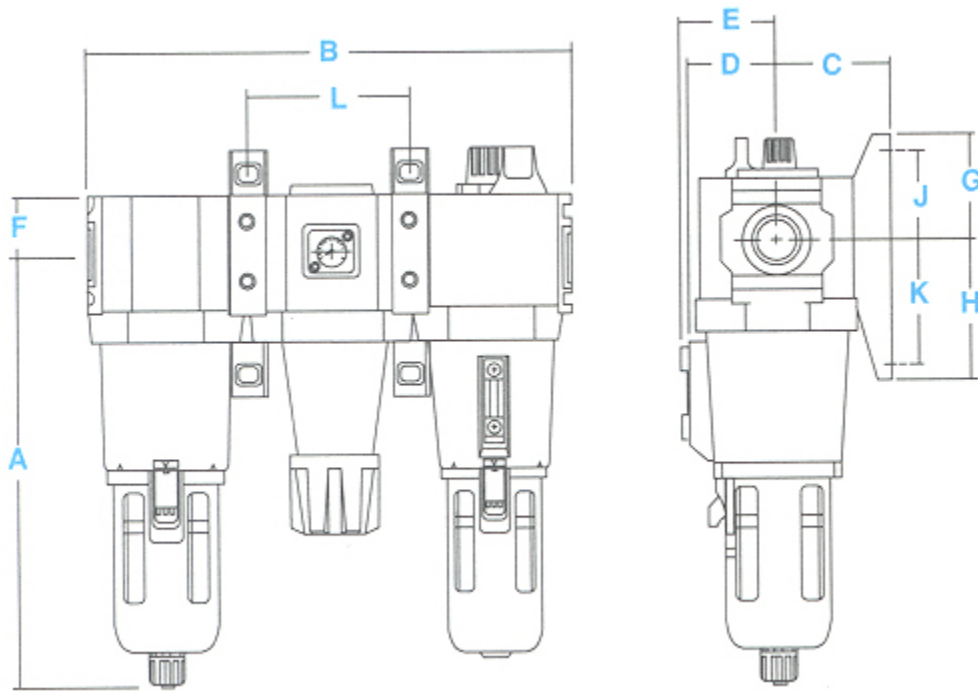

| Models   | A<br>mm<br>(inches) | B<br>mm<br>(inches) | C<br>mm<br>(inches) | D<br>mm<br>(inches) | E<br>mm<br>(inches) | F<br>mm<br>(inches) | G<br>mm<br>(inches) | H<br>mm<br>(inches) | J<br>mm<br>(inches) | K<br>mm<br>(inches) | L<br>mm<br>(inches) |
|--|---------------------|---------------------|---------------------|---------------------|---------------------|---------------------|---------------------|---------------------|---------------------|---------------------|---------------------|
| Standard Unit<br>C38-XX-FK00   | 248<br>(9.76)       | 300<br>(11.8)       | 65<br>(2.6)         | 50<br>(1.97)        | 52.5<br>(2.07)      | 33<br>(1.3)         | 65<br>(2.6)         | 85<br>(3.35)        | 50<br>(1.97)        | 70<br>(2.76)        | 100<br>(3.93)       |
| Plastic Bowl with<br>Manual Drain and<br>Pressure Gauge<br>C38-XX-FKG0 | 248<br>(9.76)       | 300<br>(11.8)       | 65<br>(2.6)         | 50<br>(1.97)        | 52.5<br>(2.07)      | 33<br>(1.3)         | 65<br>(2.6)         | 85<br>(3.35)        | 50<br>(1.97)        | 70<br>(2.76)        | 100<br>(3.93)       |
| Metal Bowl with<br>Sight Gauge and<br>Pressure Gauge                   | 248<br>(9.76)       | 300<br>(11.8)       | 65<br>(2.6)         | 50<br>(1.97)        | 52.5<br>(2.07)      | 33<br>(1.3)         | 65<br>(2.6)         | 85<br>(3.35)        | 50<br>(1.97)        | 70<br>(2.76)        | 100<br>(3.93)       |

