

TECHNICAL SPECIFICATION

Filter – F08



Product Description



Performance



Construction



Accessories and Spare Parts



How to Order



Dimensional Details



PRODUCT DESCRIPTION

Wilkerson F Series Air Filters are highly efficient at removing dirt, rust, pipe scale and other particulate contaminants down to 5 microns in size - and are over 97% efficient at separating out liquid water and oils with low pressure drops at rated flows!

Features

- Extremely efficient at water separation/removal (>97%)
- Special Whirl-Flo baffle creates a cyclonic flow, ensuring maximum separation of dirt and water from air.
- 5 micron element has always been Wilkerson's standard.
- Sintered depth-type element for high dirt-holding capacity.
- Standard bowl guard with multiple viewing slots.
- Barbed manual drain connection with pipe-away.
- Bayonet-type bowl mount for ease of service.
- Can be installed modular or hard-piped.

Operation

Separation

Air enters at inlet port (A) and flows through the Whirl-flo baffle (B), creating a cyclonic swirling flow (C). Liquids and large solid particles are centrifugally forced to the inner wall of the bowl, where gravity moves them to the quiet zone (F), below the quiet zone baffle (D), which prevents re-entrainment of the collected liquids into the air stream. Accumulated liquids are drained off by opening the manual drain valve (G).



Filtration

After liquids and large solid particles are separated from the air stream, the air then flows through the element (E), where dirt particles down to 5 microns in size are filtered out. The filtered air stream exits the filter (H) and continues downstream.

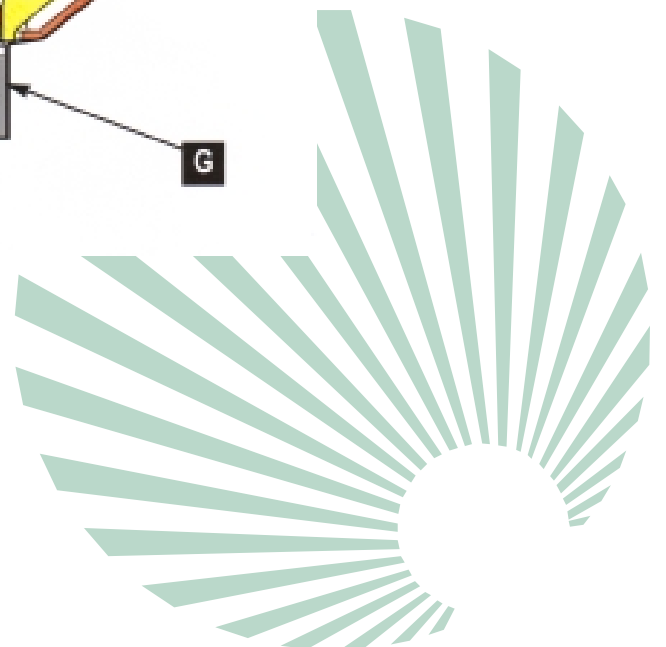
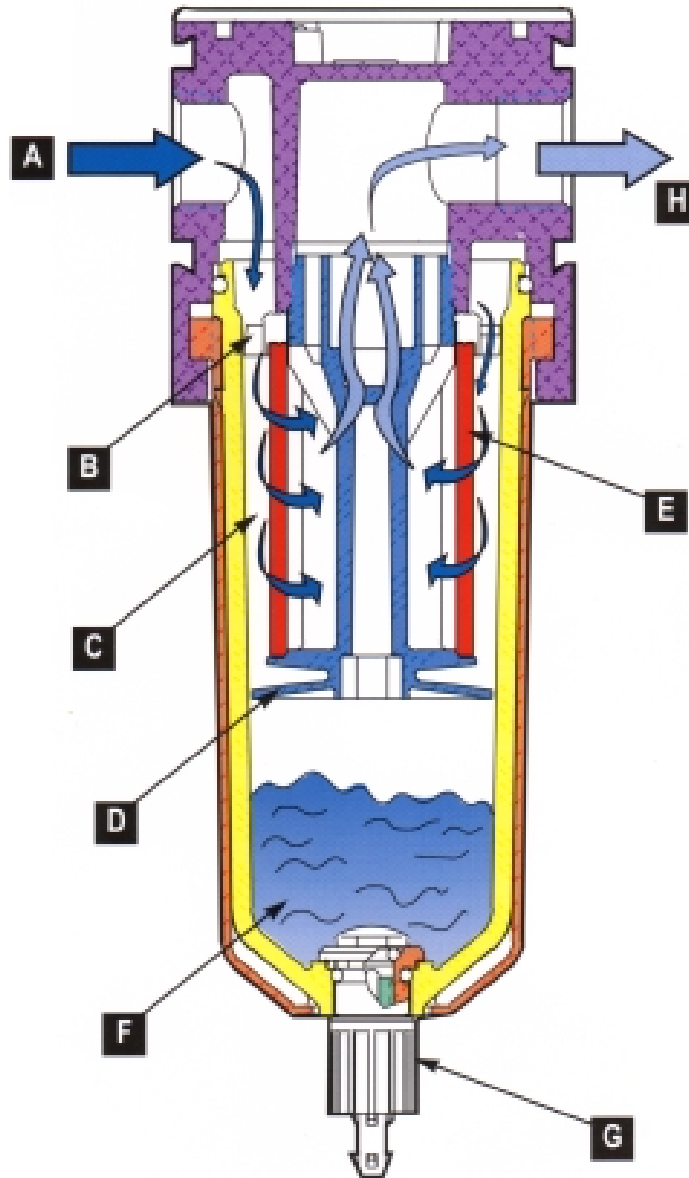

PERFORMANCE

Port Size	BSPP-G (ISO228)	1/8, 1/4
Flow Capacity*	1/8 1/4	25 scfm (11,8 dm ³ /s) 50 scfm (23,5 dm ³ /s)
Maximum Operating Temperature	Plastic Bowl Metal Bowl	125°F (52°C) 150°F (65,5°C)
Maximum Supply Pressure	Plastic Bowl Metal Bowl	150 psig (10,3 bar) 250 psig (17,2 bar)
Standard Filtration	Micron	5
Useful Retention**	oz (cm ³)	0.4 (12)
Weight	lb (kg)	0.42 (0,2)

* Inlet pressure 150 psig (10,3 bar). Pressure drop 5 psid (0,3 bar).

** Useful retention refers to volume below the quiet zone baffle.

"F" Series Filters, Type "A" 5 micron elements

All Wilkerson Type "A" 5 micron elements meet or exceed ISO Class 3 for maximum particle size and concentration of solid contaminants.



CONSTRUCTION

Body		Zinc
Body Cap		ABS
Bowl	Plastic Bowl Metal Bowl	Polycarbonate Zinc
Bowl Guard		Nylon
Element Retainer		Acetal
Baffle		Acetal
Filter Element		Sintered Polyethylene
Seals	Plastic Bowl Metal Bowl	Nitrile Nitrile



ACCESSORIES AND SPARE PARTS

Replacement Bowl Kits

Plastic Bowl/Bowl Guard, Manual Drain

GRP-96-712

Metal Bowl, Manual Drain

GRP-96-714

Replacement Element Kit

Type A 5 micron

FRP-96-729

Accessories

Automatic Piston Drain

GRP-96-716

Wall Mounting Bracket, C-Type

GPA-97-010

Wall Mounting Bracket, T-Type

GPA-96-737



HOW TO ORDER

Particulate Filter Numbering System

F 1 8 - 0 3 - S L 0 0

F Unit Function

F = Filter

1 Family

8 08 = Miniature

18 = Compact

28 = Standard

38 = Jumbo (Some bowl configurations are not available for the F38 Series Filter. Refer to Price List)

0 Thread Type

0 = NPT

C = BSPP (ISO, R228 [G Series])

3 Pipe Size

1 = 1/8

4 = 1/2

2 = 1/4

6 = 3/4

3 = 3/8

8 = 1

S Filter Element

0 = No element

S = 5 Micron

L Bowls/Drains

Drains

Plastic w/guard
Nitrile Standard

Metal w/sight glass¹
Fluorocarbon Standard

None

C

D

1/8 NPT Female²

E

F

Std Auto Drain²

G

H

Manual Drain

K

L

Low Flow Auto Drain²

N

P

Piston Drain (B08 only)

R

S

¹F08 Filter has an all metal bowl (no sight gauge)

²Except 08 Series

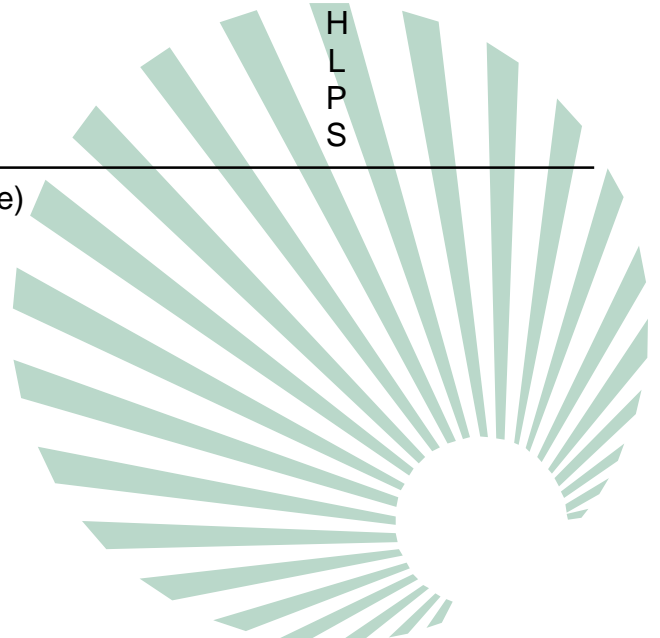

0 Options

- 0 = None
- L = Differential pressure indicator
(Not available on F08 and F38 Series Filter)
- V = Fluorocarbon Seals

0 Options

- 0 = None
- L = Differential pressure indicator
(Not available on F08 and F38 Series Filter)
- V = Fluorocarbon Seals

Note: When selecting from the options columns, please enter letters in alphabetical order, for example:

F18 – 03 – S L 0 0

"F" Series Filters, Type "A" 5 micron elements

All Wilkerson Type "A" 5 micron elements meet or exceed ISO Class 3 for maximum particle size and concentration of solid contaminants.

Note: All classes above refer to International Standards Organisation (ISO) standard 8573-1:1991 (E), pertaining to maximum particle size and concentration of solid contaminants, and maximum oil content.



DIMENSIONAL DETAILS

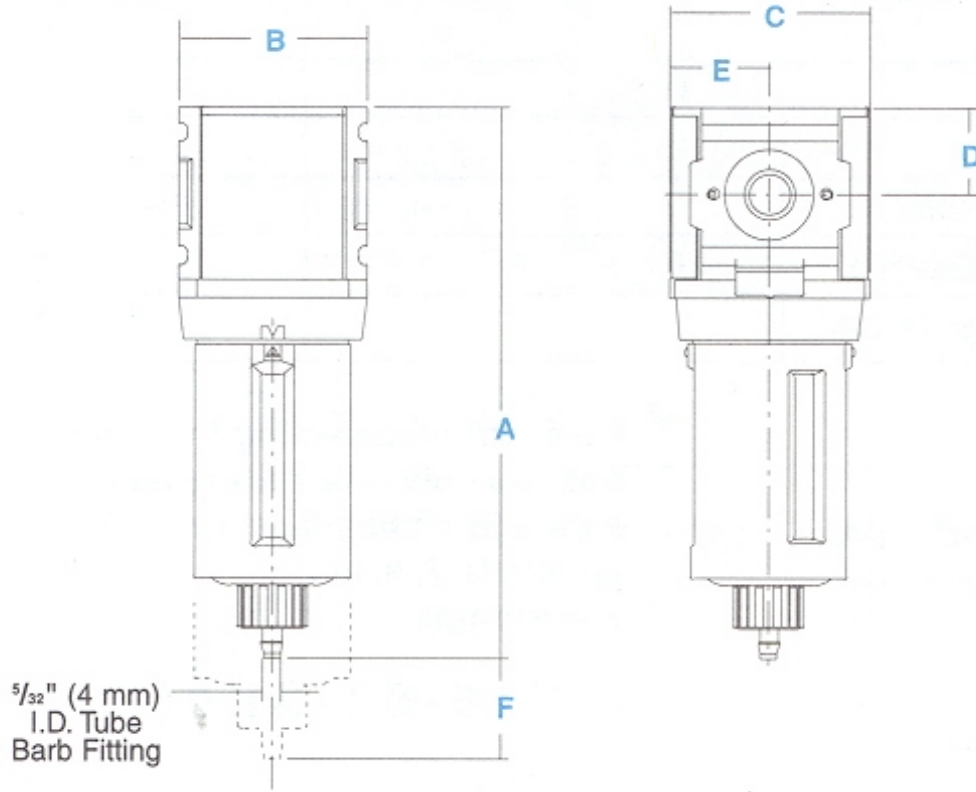

Models	A mm (inches)	B mm (inches)	C mm (inches)	D mm (inches)	E mm (inches)	F mm (inches)
Standard Unit F08-XX-SK00	116.3 (4.58)	40.0 (1.58)	42.7 (1.68)	18.3 (0.72)	21.3 (0.84)	33.3 (1.31)
Automatic Piston Drain F08-XX-SR00	116.3 (4.58)	40.0 (1.58)	42.7 (1.68)	18.3 (0.72)	21.3 (0.84)	33.3 (1.31)

