

TECHNICAL SPECIFICATION

Regulator – R18



Product Description



Performance



Construction



Accessories and Spare Parts



How to Order



Dimensional Details



PRODUCT DESCRIPTION

Wilkerson. R Series Air Regulators are designed with balanced valves for high performance flows and good regulation characteristics in a compact package.

Features

- Balanced valve design for better performance at higher flows.
- Non-rising knob with snap lock is standard.
- Diaphragm design for optimum sensitivity, response and repeatability.
- Panel nut is standard.
- 2 gauge ports standard.
- Wide range of available spring ranges and port sizes.
- Easy service access to main valve assembly.
- Reverse flow option available.
- Can be installed modular or hard piped.

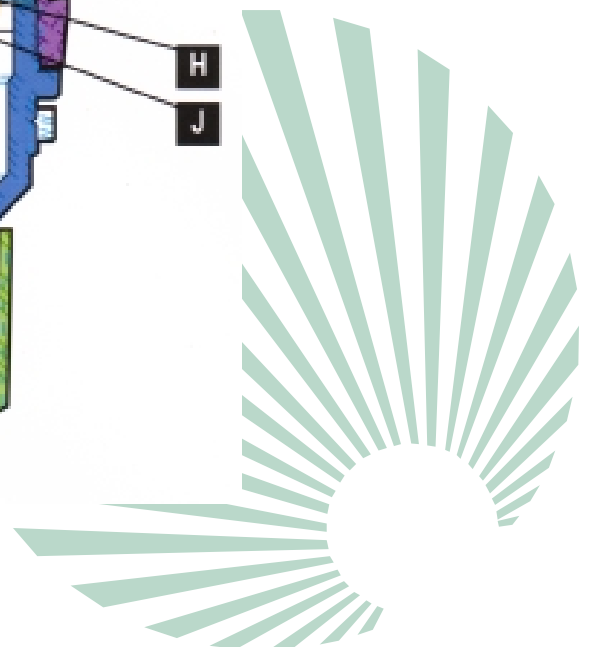
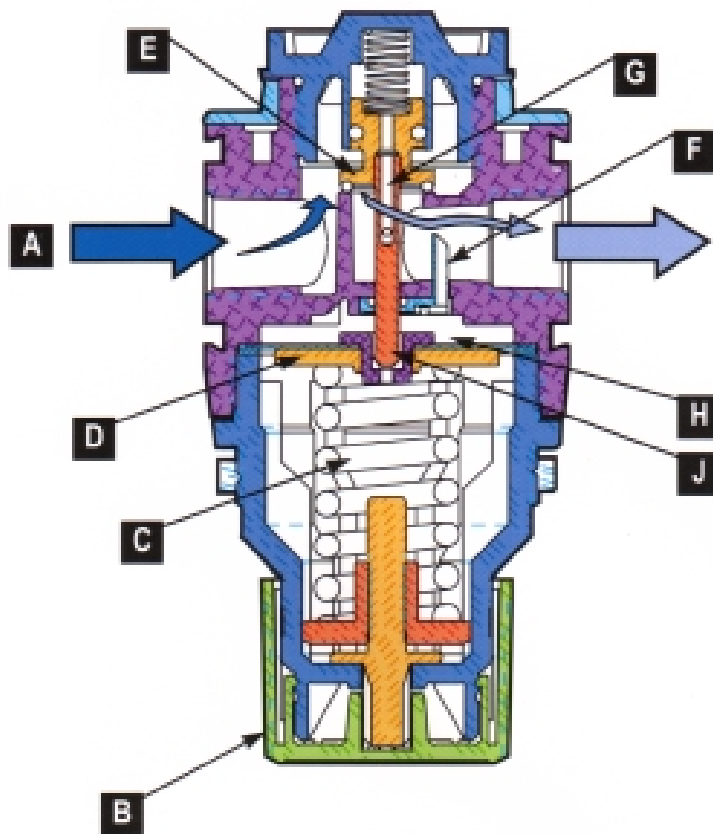

Operation

Air flow enters regulator at (A). Turning adjusting knob (B) clockwise [viewed from knob end] compresses the main spring (C), causing diaphragm (D) and main valve (E) to move, allowing flow across valve seat area. Pressure in the downstream area is sensed through the aspirator tube (F) to the area under the diaphragm (H). As downstream pressure rises, it offsets the load of spring (C). The diaphragm (D) and valve (E) move to close valve against its seat, stopping air flow through regulator. Spring pressure (C) and downstream pressure (H) are in balance, at reduced outlet pressure. Any demand downstream, such as opening a valve, will cause the downstream pressure to drop. The main spring (C) will again push open the valve (E), repeating the sequence in a modulating fashion to maintain the downstream pressure setting. In standard relieving models, a rise in downstream pressure above the set pressure will cause the diaphragm (D) to lift off the top of the valve stem (J), thus relieving the excess pressure to atmosphere under the knob (B). When the downstream pressure returns to the set pressure, the diaphragm re-seats on the valve stem, and the system is again in equilibrium.



PERFORMANCE

Port Size	BSPP-G (ISO228)	1/4, 3/8, 1/2
Flow Capacity*	1/4	82 scfm (38,7 dm ³ /s)
	3/8	97 scfm (48,1 dm ³ /s)
	1/2	97 scfm (45,8 dm ³ /s)
Maximum Operating Temperature	150°F (65,5°C)	
Maximum Supply Pressure	300 psig (20,7 bar)	
Adjusting Range Pressure	0-30 psig (0-2, 1 bar)	
	0-60 psig (0-4,1 bar)	
	0-125 psig (0-8, 6 bar)	
	0-250 psig (0-17, 2 bar)	
Gauge Port (2 each)	BSPP-G	1/4
Weight	lb (kg)	1.16 (0,5)

* Inlet pressure 100 psig (6,9 bar). Secondary pressure 90 psid (6,2 bar).



CONSTRUCTION

Body		Zinc
Adjustment Knob		Acetal
Body Cap		ABS
Bonnet		33% glass filled nylon
Diaphragm Assembly		Nitrile/Zinc
Bottom Plug		33% glass filled nylon
Valve Assembly		Brass/Nitrile
Seals		Nitrile
Springs	Main Regulating Valve	Steel/S.S.
Panel Nut		Acetal



ACCESSORIES AND SPARE PARTS

Replacement Bowl Kits

Diaphragm Assembly, Relieving	RRP-96-656
Diaphragm Assembly, Non-Relieving	RRP-96-657
Valve Assembly	RRP-96-658
Spring, Regulating 0-30 psig (0-1,7 bar)	RRP-96-659
Spring, Regulating 0-60 psig (0-4,1 bar)	RRP-96-660
Spring, Regulating 0-125 psig (0-8,5 bar)	RRP-96-661
Spring, Regulating 0-250 psig (0-17 bar)	RRP-96-662
Adjusting Knob	RRP-16-341-000

Accessories

Gauge, Pressure, 0-30 psig 1 1/2 Dial Face, 1/4 NPT, CBM	RRP-96-663
Gauge, Pressure, 0-60 psig 1 1/2 Dial Face, 1/4 NPT, CBM	RRP-96-664
Gauge, Pressure, 0-160 psig 1 1/2 Dial Face, 1/4 NPT, CBM	RRP-96-665
Gauge, Pressure, 0-300 psig 1 1/2 Dial Face, 1/4 NPT, CBM	RRP-96-666
Gauge, Pressure, 0-2 bar, 1 1/2 Dial Face, G 1/4 CBM	RRP-96-667
Gauge, Pressure, 0-4, 1 bar, 1 1/2 Dial Face, G 1/4 CBM	RRP-96-668
Gauge, Pressure, 0-11 bar, 1 1/2 Dial Face, G 1/4 CBM	RRP-96-669
Gauge, Pressure, 0-21 bar, 1 1/2 Dial Face, G 1/4 CBM	RRP-96-670
Wall Mounting Bracket, L-Type	GPA-96-606
Wall Mounting Bracket, T-Type	GPA-96-602
Tamper Resistant Kit	RRP-96-671
Plastic Panel Nut	RPA-96-735
Panel Mount Nut, Aluminum	RRP-96-673
Panel Mount Nut, Plastic	RRP-96-675



HOW TO ORDER

Regulator Numbering System

R 1 8 - 0 3 - F 0 G 0

R Unit Function

R = Regulator

1 Family

8 08 = Miniature
 18 = Compact
 28 = Standard
 38 = Jumbo

0 Thread Type

0 = NPT
 C = BSPP (ISO, R228 [G Series])

3 Pipe Size

1 = 1/8	4 = 1/2
2 = 1/4	6 = 3/4
3 = 3/8	8 = 1

F Regulator

Diaphragm Function	Fluorocarbon	Spring Range			
		0-30 psi (0-2,1 Bar)	0-60 psi (0-4,1 Bar)	0-125 psi (0-8,5 Bar)	0-250 psi (0-17 Bar)
Relieving	No	C	D	F	G
	Yes	J	K	L	M
Non-relieving	No	P	Q	R	S
	Yes	V	X	Y	Z

0 Options

0 = None

G Options

0 = None
 E = Bar Gauge (Except 38 Series)
 C = Tamper Resistant Regulator Adj (Tamper kit not installed. Kit is shipped loose in carton)
 G = Pressure Gauge
 P = Metal Panel Nut (Except 38 Series)
 R = Reverse Flow

0 Options

0 = None
 E = Bar Gauge (Except 38 Series)
 C = Tamper Resistant Regulator Adj (Tamper kit not installed. Kit is shipped loose in carton)
 G = Pressure Gauge
 P = Metal Panel Nut (Except 38 Series)
 R = Reverse Flow
 K = Pressure Gauge mounted on back side (R08 only)

Note: When selecting from the options columns, please enter letters in alphabetical order, for example:

R18-03-F 0 G 0

DIMENSIONAL DETAILS

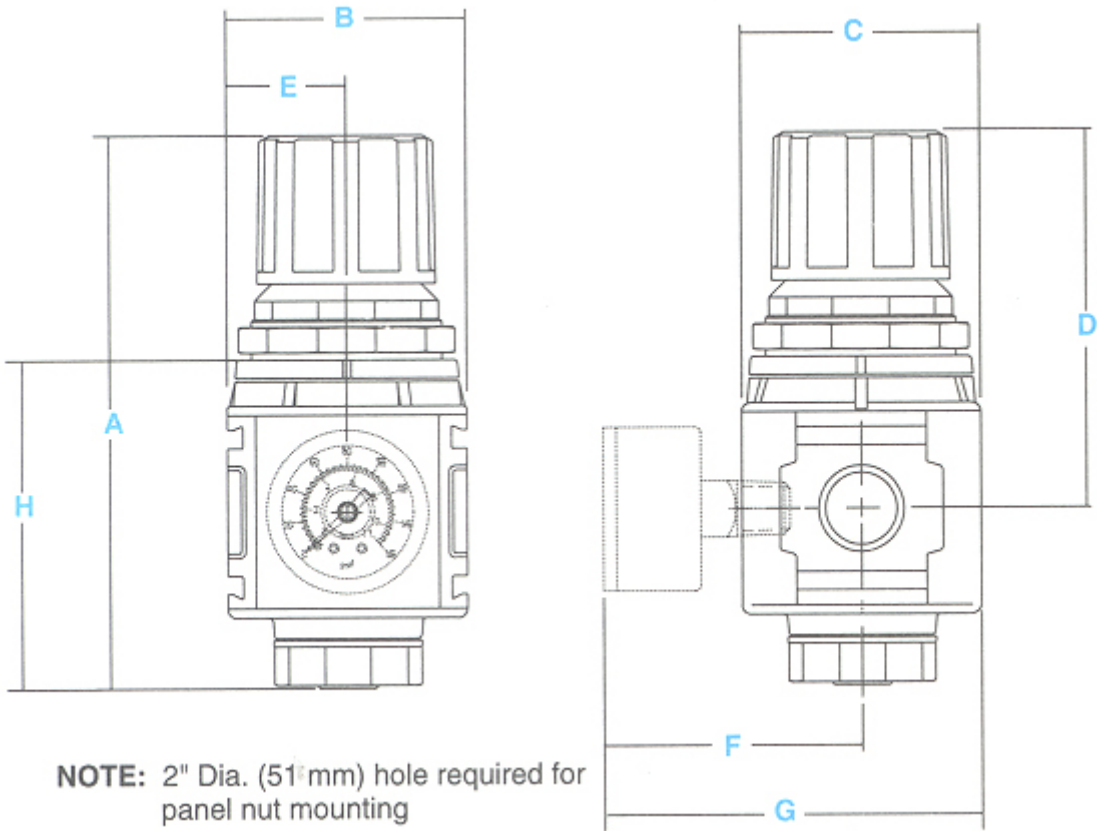

Models	A mm (inches)	B mm (inches)	C mm (inches)	D mm (inches)	E mm (inches)	F mm (inches)	G mm (inches)	H mm (inches)
Standard Unit R18-XX-F000	136 (5.4)	60 (2.36)	60 (2.36)	93 (3.66)	30 (1.2)	-	-	78.7 (3.1)
With Gauge R18-XX-F0G0	136 (5.4)	60 (2.36)	60 (2.36)	93 (3.66)	30 (1.2)	65 (2.57)	94 (3.74)	78.7 (3.1)

