

TECHNICAL SPECIFICATION

Filter Regulator – B08



Product Description



Performance



Construction



Accessories and Spare Parts



How to Order



Dimensional Details



PRODUCT DESCRIPTION

Wilkerson B Series Integral Filter/Regulator Combo Units integrate the excellent features of the F Series filters and the R Series regulators into a high performance space-saving package. Filtration down to 5 microns in size – >97% efficient at separating out liquid water and oils with low pressure drops at rated flows – Excellent regulation characteristics, all in an economical and smartly-styled package.

Features

- Extremely efficient at water separation/removal (>97%)
- Special Whirl-Flo baffle creates a cyclonic flow, ensuring maximum separation of dirt and water from air
- 5 micron filter element - Wilkerson's standard
- Space-saving package combines filter and regulator into one integral unit.
- Balanced valve design for better performance at higher flows.
- Bayonet-type bowl mount for ease of service.
- Excellent response, repeatability, and sensitivity because of diaphragm design.
- Manual drain with pipe-away
- Can be installed modular or hard-piped.

Operation

Turning adjusting knob (H) clockwise [viewed from top of knob] compresses main spring (I), moving diaphragm (J) and valve (K) down, which allows filtered air to flow past valve seat and downstream.

Separation

Air enters at inlet port (A) and flows through the Whiri-Flo baffle (B), creating a cyclonic swirling flow (C). Liquids and large solid particles are centrifugally forced to the inner wall of the bowl, where gravity moves them to the quiet zone (F), below the quiet zone baffle (D), which prevents re-entrainment of the collected liquids into the air stream. Accumulated liquids are drained off by opening the manual drain valve (G).

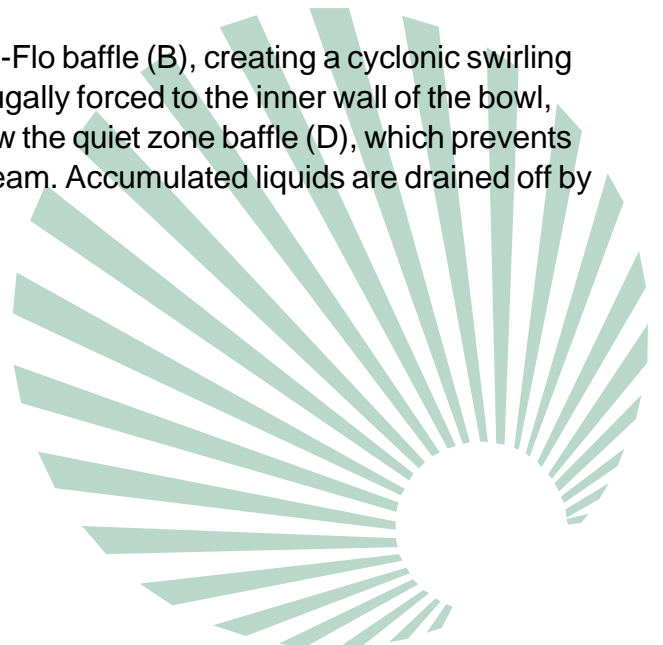

Filtration

After liquids and large solid particles are separated from the air stream, the air then flows through the element (E), where dirt particles down to 5 microns in size are filtered out. The filtered air stream exits the filter and flows across the valve seat and continues downstream (M). Pressure in the downstream line is sensed through the aspirator tube (R), at the underside of the diaphragm (L), offsetting the load of the main spring (I). When the downstream pressure reaches the set-point, the diaphragm (J) moves up, allowing the main valve (K) to move up, stopping air flow across the valve seat. In standard relieving models, a rise in downstream pressure above the set pressure will cause the diaphragm (J) to lift off the top of the valve stem (K), allowing the excess pressure to be vented through the relieving hole (N) in the centre of the diaphragm. The vented air passes to atmosphere under the knob (H).

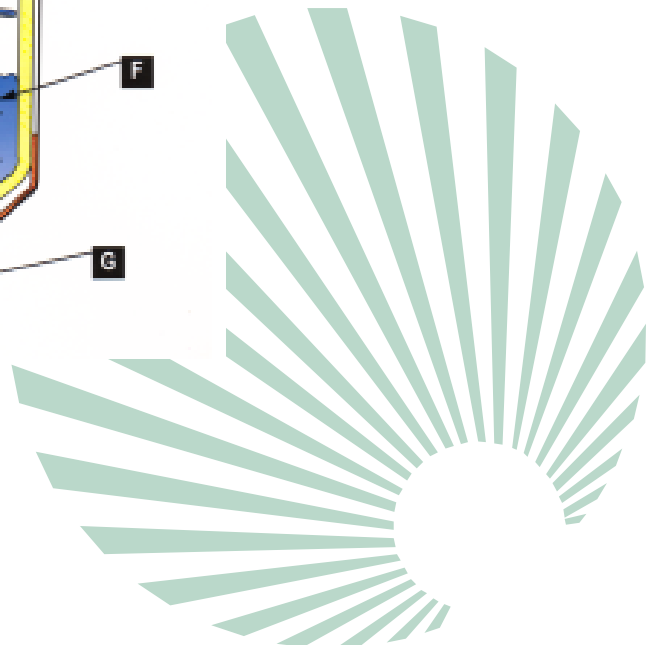
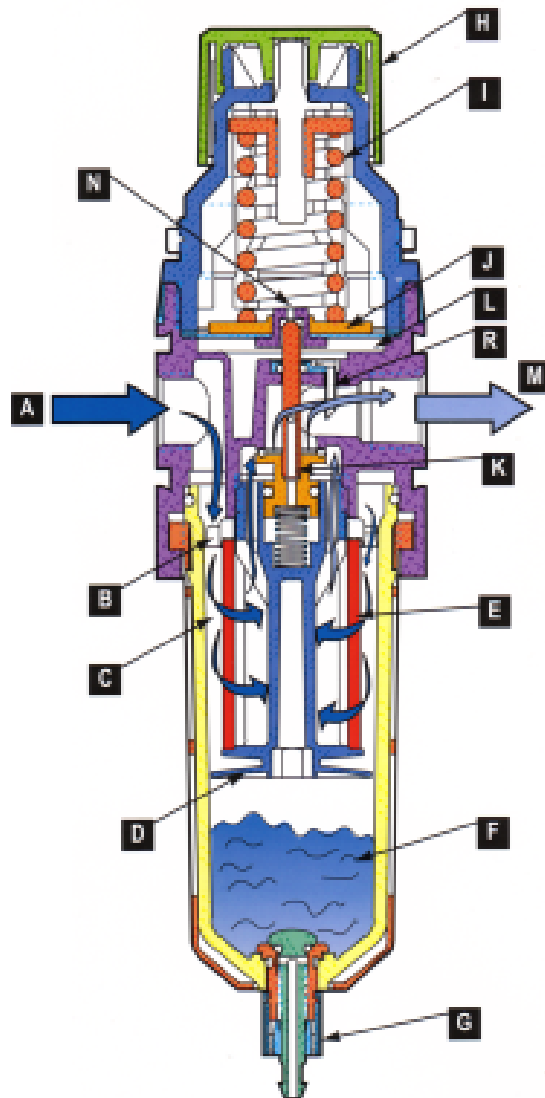

PERFORMANCE

Port Size	BSPP-G (ISO228)	1/8, 1/4
Flow Capacity*	1/8 1/4	28 scfm (13,2 dm ³ /s) 44.0 scfm (19,8 dm ³ /s)
Maximum Operating Temperature	Plastic Bowl Metal Bowl	125°F (52°C) 150°F (65,5°C)
Maximum Supply Pressure	Plastic Bowl Metal Bowl	150 psig (10,3 bar) 250 psig (17,2 bar)
Standard Filtration	Micron	5
Useful Retention**	oz (cm ³)	0.4 (12)
Adjusting Range Pressure	0-60 psig (0-4,1 bar) 0-30 psig (0-2, 1 bar) 0-125 psig (0-8, 6 bar)	
Weight	lb (kg)	0.66 (0,3)

* Inlet pressure 100 psig (6,9 bar). Secondary pressure 90 psid (6,2 bar).

** Useful retention refers to volume below the quiet zone baffle.

"F" Series Filters, Type "A" 5 micron elements

All Wilkerson Type "A" 5 micron elements meet or exceed ISO Class 3 for maximum particle size and concentration of solid contaminants.



CONSTRUCTION

Body		Zinc
Adjustment Knob		Acetal
Body Cap		ABS
Bonnet		PBT
Bowl	Plastic Bowl Metal Bowl	Polycarbonate Zinc
Bowl Guard		Nylon
Filter Element		Polyethylene
Seals	Plastic Bowl Metal Bowl	Nitrile Nitrile
Springs		Steel
Valve Assembly		Brass/Nitrile
Diaphragm Assembly		Brass/Nitrile
Panel Nut		Acetal



ACCESSORIES AND SPARE PARTS

Replacement Bowl Kits

Metal Bowl, Manual Drain	GRP-96-714
Plastic Bowl/Bowl Guard, Manual Drain	GRP-96-712

Replacement Element Kit

Type A 5 micron	FRP-96-729
-----------------	------------

Replacement Kits

Adjusting Knob	RRP-16-005-000
Diaphragm Assembly, Relieving	GRP-96-725
Diaphragm Assembly, Non-Relieving	GRP-96-726
Valve Assembly	RRP-96-727
Spring, Regulating 0-30 psig (0-2,1 bar)	GRP-95-111
Spring, Regulating 0-60 psig (0-4,1 bar)	GRP-96-718
Spring, Regulating 0-125 psig (0-8,5 bar)	GRP-96-717

Accessories

Gauge Adapter Block, 1/4" npt,	GPA-97-037
Replaces flush mount gauge Automatic Piston Drain	GRP-96-716
Gauge, Pressure, Flush Mounted 0-60 psig	GRP-96-720
Gauge, Pressure, Flush Mounted 0-160 psig	GRP-96-719
Gauge, Pressure, Flush Mounted 0-2,0 bar	GRP-96-724
Gauge, Pressure, Flush Mounted 0-4,1 bar	GRP-96-723
Gauge, Pressure, Flush Mounted 0-11 bar	GRP-96-722
Gauge, Pressure, 0-60 psig (0-4, 1 bar), 1-1/2 Dial Face, 1/8 NPT, CBM	GRP-95-228
Gauge, Pressure, 0-160 psig (0-11, 0 bar), 1-1/2 Dial Face, 1/8 NPT, CBM	GRP-95-227
Wall Mounting Bracket, C-Type	GPA-97-010
Wall Mounting Bracket, L-Type	GRP-96-739
Tamper Resistant Kit	RPA-96-735
Panel Mount Nut, Plastic	RPA-96-734
Panel Mount Nut, Aluminum	RPA-96-733



HOW TO ORDER

Filter/Regulator Numbering System

B 1 8 - 0 3 - F H G P

B Unit Function

B = Filter/Regulator Combination

1 Family

8 08 = Miniature
 18 = Compact
 28 = Standard
 38 = Jumbo (Not all configurations available for the B38 Series Filter/Regulator Refer to price list.)

0 Thread Type

0 = NPT
 C = BSPP (ISO, R228 [G Series])

3 Pipe Size

1 = 1/8	4 = 1/2
2 = 1/4	6 = 3/4
3 = 3/8	8 = 1

F Filter/Regulator Combination

Diaphragm Function	Fluorocarbon	Spring Range			
		0-30 psi (0-2,1 Bar)	0-60 psi (0-4,1 Bar)	0-125 psi (0-8,5 Bar)	0-250 psi (0-17 Bar)
Relieving	No	C	D	F	G
	Yes	J	K	L	M
Non-relieving	No	P	Q	R	S
	Yes	V	X	Y	Z

H Bowls/Drains

Drains	Plastic w/guard Nitrile Standard	Metal w/sight glass ¹ Fluorocarbon Standard
	None	C
Std Auto Drain ²	G	H
Manual Drain	K	L
Low Flow Auto Drain ²	N	P
Piston Drain (B08 only)	R	S

¹B08 Filter/Regulator has an all metal bowl (no sight gauge)

²Except 08 Series

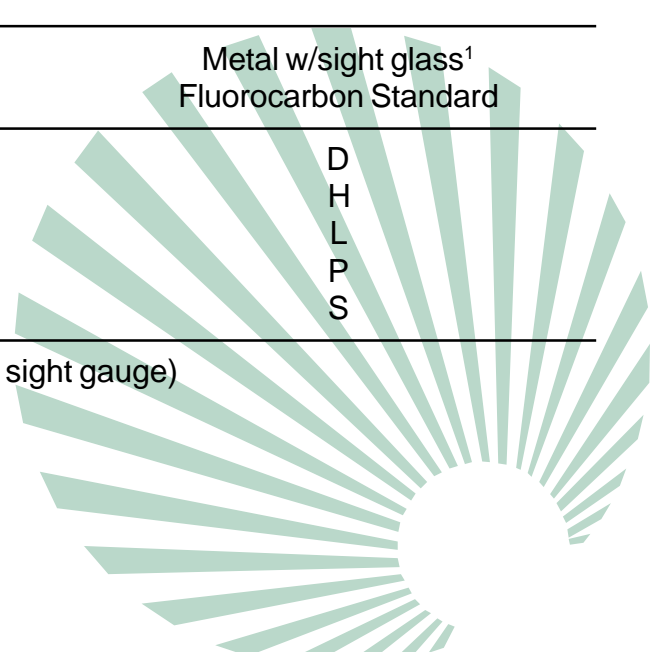

G Options

- 0 = None
- E = Bar Gauge (Except 38 Model)
- C = Tamper Resistant Regulator Adj (Tamper kit not installed.
Kit is shipped loose in carton)
- G = Pressure Gauge
- P = Metal Panel Nut (Except 38 Model)

P Options

- 0 = None
- E = Bar Gauge (Except 38 Model)
- C = Tamper Resistant Regulator Adj (Tamper kit not installed.
Kit is shipped loose in carton)
- G = Pressure Gauge
- P = Metal Panel Nut (Except 38 Model)
- K = Pressure Gauge mounted on back side (B08 only)

Note: When selecting from the options columns, please enter letters in alphabetical order, for example:

B18 – 03 – F H G P

"F" Series Filters, Type "A" 5 micron elements

All Wilkerson Type "A" 5 micron elements meet or exceed ISO Class 3 for maximum particle size and concentration of solid contaminants.

Note: All classes above refer to International Standards Organisation (ISO) standard 8573-1:1991 (E), pertaining to maximum particle size and concentration of solid contaminants, and maximum oil content.



DIMENSIONAL DETAILS

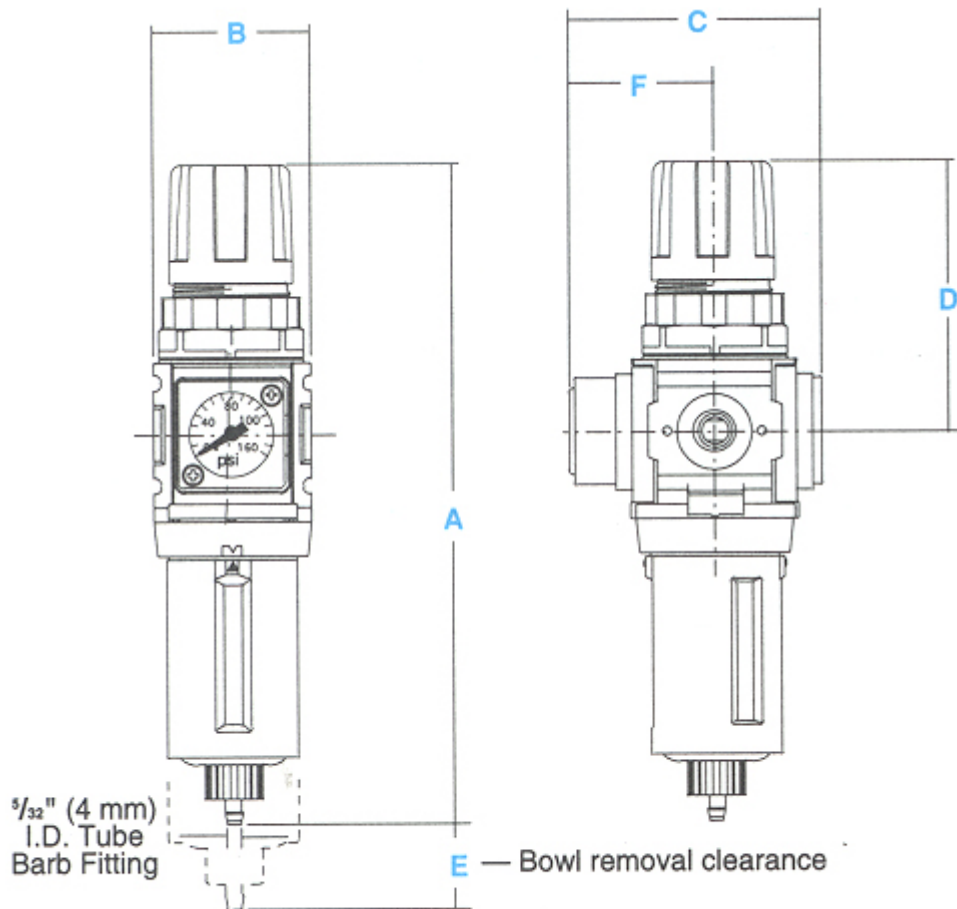

Note: Flush-mounted gauge kits will not fit units originally purchased with threaded gauge ports.

Models	A mm (inches)	B mm (inches)	C mm (inches)	D mm (inches)	E mm (inches)	F mm (inches)
Standard Unit B08-XX-FK00	164.1 (6.46)	40.0 (1.58)	43.1 (1.70)	66.0 (2.60)	33.3 (1.31)	21.6 (0.85)
Automatic Piston Drain B09-XX-FRG0	164.1 (6.46)	40.0 (1.58)	64.3 (2.53)	66.0 (2.60)	33.3 (1.31)	36.8 (1.45)